

***DT*** SWISS

**CLASSIC** WHEELS  
TECHNICAL MANUAL

V2022.09

<b>1. GENERAL</b> .....	<b>3</b>
1.1 VALIDITY.....	3
1.2 SAFETY.....	3
1.3 TARGET GROUP.....	3
1.4 LAYOUT.....	3
1.5 DT SWISS MANUAL CONCEPT.....	3
1.6 GENERAL MAINTENANCE INFORMATION.....	4
1.7 ENVIRONMENTAL PROTECTION.....	4
1.8 EXCLUSION OF LIABILITY.....	4
1.9 WARRANTY.....	4
<b>2. CONVERTING THE END CAPS</b> .....	<b>5</b>
2.1 CONVERTING THE END CAPS ON THE FRONT WHEEL.....	5
2.2 CONVERTING THE END CAPS ON THE REAR WHEEL.....	7
<b>3. HUB MAINTENANCE</b> .....	<b>9</b>
3.1 SERVICE INTERVALS.....	9
3.2 SAFETY.....	10
3.3 MAINTENANCE OF THE REAR WHEEL HUB WITH RATCHET SYSTEM.....	11
<b>4. MAINTENANCE OF THE WHEEL</b> .....	<b>17</b>
4.1 SERVICE INTERVALS.....	17
4.2 SAFETY.....	17
4.3 PHR SYSTEM: BASICS.....	18
4.4 REPLACING A SPOKE.....	19
<b>5. TROUBLE SHOOTING</b> .....	<b>22</b>
5.1 TROUBLE SHOOTING HUBS.....	22
5.2 TROUBLE SHOOTING WHEELS.....	23
<b>6. TECHNICAL DATA</b> .....	<b>24</b>
6.1 SPOKE TENSION.....	24
6.2 TOLERANCES.....	24

# 1. GENERAL

## 1.1 VALIDITY

This manual describes the component specified on the front page and the footer. This manual is valid for the design of the product as of 27.09.22. Deviations are possible and all items are subject to technical changes.

## 1.2 SAFETY

The safety instructions are classified as follows:



### DANGER

...indicates a hazardous situation that, if not avoided, will result in death or serious injury.



### CAUTION

... indicates a hazard with a medium level of risk which, if not avoided, may result in minor or moderate injury.



### NOTE

... indicates a potentially hazardous situation that may result in damage to property.

## 1.3 TARGET GROUP

This manual is intended for the user of the component and dealers. This manual offers the experienced user the possibility to carry out minor service work himself. If you have any doubts about your own abilities, you should definitely contact an expert or a DT Swiss Service Center.

Any warranty claims will lapse if work is not carried out properly.

## 1.4 LAYOUT

The cover page and the footing provide information about the type of product and manual as well as the version of the manual. The DT Swiss contact details can be found on the back. A list of all DT Swiss service centers can be found at [www.dtswiss.com](http://www.dtswiss.com).

This manual is intended for being printed as an A5 booklet. Only print this manual if electronic usage is not possible.

## 1.5 DT SWISS MANUAL CONCEPT

The DT Swiss manuals are split into the following types of manuals:

- User Manual: Information for the end user on how to install and use the component.
- Technical Manual: Detailed information for the end user and the dealer on how to maintain the component, spare parts and technical data.

## 1.6 GENERAL MAINTENANCE INFORMATION

Unless otherwise specified, moving parts, threads, O-rings and sealings must be greased before assembly.

### CLEANING

For an optimal result of the maintenance work, every component that will be disassembled must be cleaned. Only use cleaners and degreasers which do not damage the components. Especially the cleaning of O-rings and sealings requires mild cleaners. Observe the instructions for use of the respective cleaner.

DT Swiss recommends the following cleaners:

- Motorex Rex
- Motorex Swissclean
- Motorex OPAL 2400, 3000 OPAL, OPAL 5000

Use soap water or similar mild cleaners for external cleaning.

### TOOLS

To ensure a damage-free mounting and dismounting of the components, only use the tools which are mentioned in this manual. Special tools are indicated at the beginning of a chapter in the table "Required material".

The use of different tools is at the discretion of the user. If components are damaged by the usage of differing tools, the user is liable.

DT Swiss special tools are precision tools. Damage-free mounting and dismounting of the components can only be ensured if the tools are working properly and if the condition of the tools are perfect. Always keep the tools in their original packaging or adequate devices to prevent damage.

## 1.7 ENVIRONMENTAL PROTECTION

The statutory regulations shall apply. Whenever possible, avoid creating waste. Waste, especially carbon, lubricants, cleaners and any other fluids must be disposed in an environmentally compatible manner. Only print this manual if electronic usage is not possible.

## 1.8 EXCLUSION OF LIABILITY

The activities listed in this manual may only be carried out by persons with sufficient specialist knowledge. The user is liable for any damage or consequential damage caused by wrongly maintained or installed components. If you have doubts, please contact an expert or your region's DT Swiss pro level service center.

## 1.9 WARRANTY

Warranty conditions, see [www.dtswiss.com](http://www.dtswiss.com)

## 2. CONVERTING THE END CAPS

### 2.1 CONVERTING THE END CAPS ON THE FRONT WHEEL

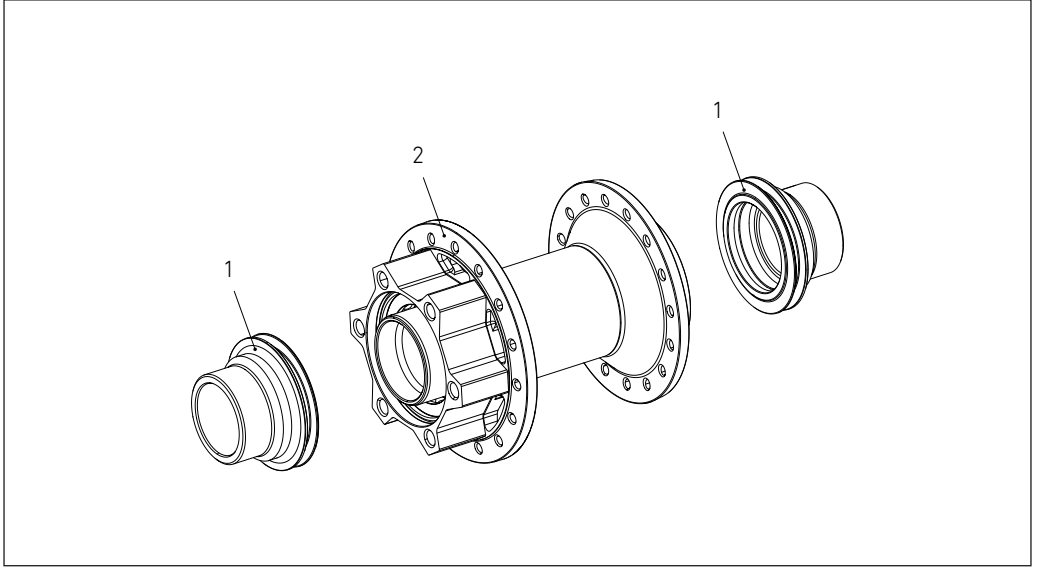

1 | end cap

2 | ball bearing

You can find the possible conversion options for your wheel at [dtswiss.com/en/support/product-support](https://dtswiss.com/en/support/product-support).

### REQUIRED WEARING PARTS AND MATERIALS

Wearing parts / Materials	Specification	Quantity	Article number
DT Swiss universal grease		20 g	HXTXXX00NMG20S

### DISMOUNTING THE END CAPS

1. Clamp one of both end caps into a vise.
2. Pull off the wheel, respectively the hub.
3. Clamp the second end cap into a vice.
4. Pull off the wheel, respectively the hub.



## CLEANING AND GREASING THE END CAPS

1. Clean both end caps and the exposed sides of the hub with a dry cloth
2. Grease both bearings and the inner side of both end caps.



## PUTTING ON THE END CAPS

1. Put on the left and the right end cap by hand.
- Caution: The shorter end cap must be placed on the drive side.



Closing Steps:	Link
Mount the brake rotor.	See specifications of the respective manufacturer.

## 2.2 CONVERTING THE END CAPS ON THE REAR WHEEL

### OVERVIEW

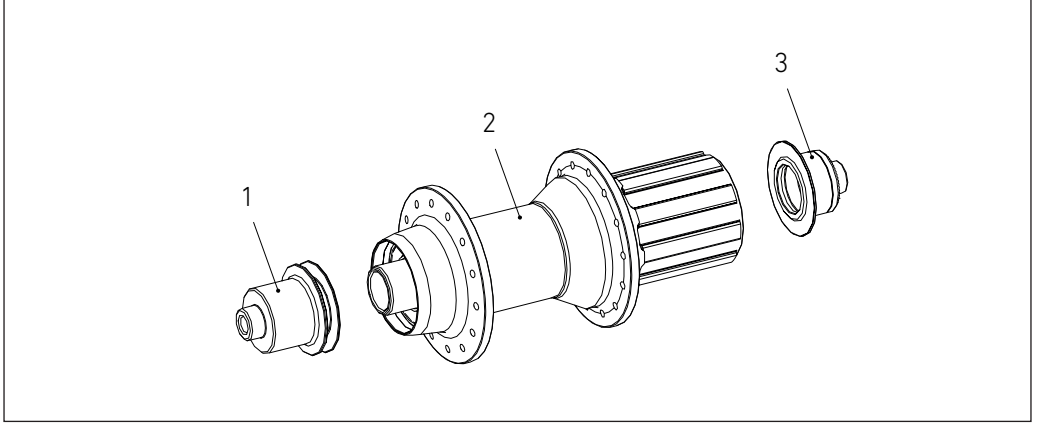

1	end cap non drive side	3	end cap drive side
2	hub shell		

You can find the possible conversion options for your wheel at [dtswiss.com/en/support/product-support](https://dtswiss.com/en/support/product-support).

### REQUIRED WEARING PARTS AND MATERIALS

Wearing parts / Materials	Specification	Quantity	Article number
DT Swiss universal grease		20 g	HXTXXX00NMG20S

### DISMOUNTING THE END CAPS

1. Clamp the left end cap into a vise.
2. Pull off the wheel, respectively the hub.
3. Clamp the right end cap into a vise.
4. Pull off the wheel, respectively the hub.



## CLEAN AND GREASE THE END CAPS

1. Clean both end caps and the exposed sides of the hub with a dry cloth
2. Grease both bearings and the inner side of both end caps.



## PUTTING ON THE END CAPS

1. Put on the left and the right end cap by hand.
- Caution: The shorter end cap must be placed on the drive side.



Closing Steps:	Link
Mount the brake rotor.	See specifications of the respective manufacturer.
Mount the cassette.	See specifications of the respective manufacturer.



## 3. HUB MAINTENANCE

### 3.1 SERVICE INTERVALS

The following regular maintenance and care work is recommended by DT Swiss:

Task	Interval
Small hub service (function check, cleaning and greasing) <ul style="list-style-type: none"><li>• Under normal operating conditions</li><li>• In case of extreme operating conditions (regular journeys in dust, rain, snow, or in case of frequent transport while raining)</li></ul>	3 months as required
Full hub service (replacement of defective parts as required, according to the technical manual of the hub).	as required
Check the tightening torques <ul style="list-style-type: none"><li>• Center Lock adapter: 40 Nm</li><li>• Screws of the brake rotor: 6 Nm</li><li>• Lock ring on the cassette: 40 Nm</li></ul>	20 operating hours
Check the functionality of the rear wheel hub. The engagement of the rear wheel hub must operate perfectly!	before each ride
Clean with soft cloth and a suitable cleaner. → Do not use high-pressure cleaners or aggressive cleaning agents!	After each ride
Check the hub for damage.	After each ride

### SMALL HUB SERVICE

During the small hub service, the following activities should be performed:

1. Dismount the end caps.
2. Clean the end caps and the underlying surfaces of the ball bearings.
3. When using a rear wheel: Remove the freewheel body and clean, check and grease the freewheel system.
4. Check the ball bearings.
  - The hub must turn smoothly.
  - The hub must not have any play in relation to the axle.
  - If there is play, or the ball bearings are running heavy or rough, a full hub service must be performed (see Hub Technical Manual).
5. Assemble the freewheel system and the freewheel body if required.
6. Grease the surfaces of the ball bearings.
7. Mount the end caps.

## FULL HUB SERVICE

The full hub service must only be carried out if malfunctions are present or faults are detected during the functional tests.

The full hub service includes the activities of the small hub service and additionally the disassembly of the ball bearings and assembly of new ball bearings as well as the disassembly of the complete freewheel system and the exchange of the corresponding spare parts.

### 3.2 SAFETY



#### **DANGER**

#### **DANGER TO LIFE DUE TO INCORRECT MAINTENANCE AND INCORRECT SPARE PARTS!**

Unpredictable malfunctions can occur due to incorrect maintenance, incorrect installation or incorrect spare parts.

- Maintenance may only be carried out by experienced specialists.
- Use only original DT Swiss spare parts or spare parts approved by DT Swiss.
- In cases of doubt, please contact a DT Swiss Service Center.

### 3.3 MAINTENANCE OF THE REAR WHEEL HUB WITH RATCHET SYSTEM

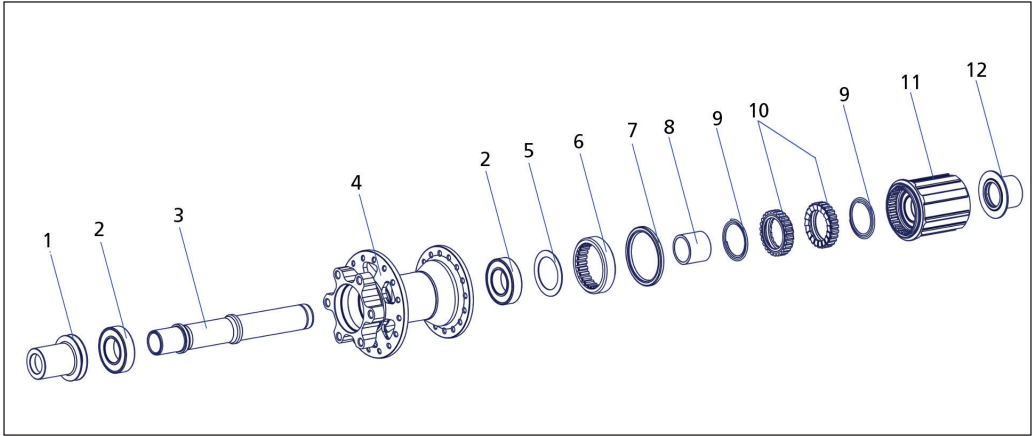

Preparations	Link
Dismount the brake rotor	See specifications of the respective manufacturer.
Dismount cassette	See specifications of the respective manufacturer.
Clean the hub	See "Cleaning" on page 4.

#### OVERVIEW



1	end cap non drive side	7	hub seal
2	ball bearing	8	spacer
3	axle	9	spring
4	hub shell	10	ratchet
5	shim ring	11	freewheel body
6	ring nut	12	end cap drive side

#### REQUIRED WEARING PARTS AND MATERIALS

Wearing parts / Materials	Specification	Quantity	Article number
DT Swiss universal grease		20 g	HXTXX00NMG20S
DT Swiss Special Grease		20 g	HXT10032508S

## REMOVING END CAPS, FREEWHEEL BODY AND FREEWHEEL SYSTEM

1. Pull off both end caps by hand.

If the end caps cannot be pulled off by hand, clamp the end caps carefully into a vise with ground clamping jaws and pull the hub / wheel upwards.



2. Pull the freewheel body off the hub.



3. Remove springs, ratchets and spacer from the hub.



## CLEANING AND CHECKING ALL PARTS

1. Thoroughly clean all parts of the hub. The existing grease must be completely removed from the hub body and from the ratchets.
2. Check the ratchets for wear.

The wear of the ratchets usually starts at the outer circumference and shows itself by strongly flattened edges with uneven wear.

In case of heavy wear, the ratchets must be changed immediately.



3. Check the freewheel body for damages.  
→ Grooves from the cassette are no damages. These are normal signs of usage.
4. Remove bad notches on the freewheel body using a file.
5. Clean the freewheel body. Metal chips and metal particles must be removed completely.

## MOUNTING THE FREEWHEEL SYSTEM



### DANGER

#### RISK OF INJURY DUE TO LIMITED FREEWHEEL FUNCTION DUE TO INCORRECT LUBRICATION!

If too much grease is applied on the ratchets, the actuation of the ratchets may not work. The ratchets may slip during pedaling.

- Only apply a thin, even layer of grease.
- Only use the red DT Swiss Special Grease.

1. Apply DT Swiss Special Grease evenly to the outer and the inner tooting of the ratchets using a fine brush.  
→ For an optimal functionality of the freewheel system, a thin layer of grease is sufficient.



2. Grease the teeth of the freewheel body and the ring nut with DT Swiss Special Grease.



3. Attach the spacer and the first spring.  
→ The spring must rest on the hub with its large diameter.



4. Attach both ratchets and the second spring.
5. The spring must rest with its small diameter on the ratchet.



### PUTTING ON THE FREEWHEEL BODY AND THE END CAPS

1. Put the freewheel body onto the hub.
2. Check if the freewheel body can be turned and if the ratchets are engaging.



3. Grease the bearings and the inner surface of both end caps.



4. Put on the left and the right end cap.
  - The shorter end cap must be placed on the drive side.
5. Push in end caps by hand.



## CHECK THE FUNCTIONALITY

1. Turn the freewheel body in both directions.
  - The freewheel body can be turned counterclockwise easily.  
The ratchets engage audibly and perceptibly.
  - The freewheel body cannot be turned clockwise.
2. Check the tightness of the end caps.
  - The end caps are firmly seated on the axle and are fully pushed on.

Closing Steps	Link
Clean the hub.	See "Cleaning" on page 4.
Mount the cassette.	See specifications of the respective manufacturer.
Mount the brake rotor.	See specifications of the respective manufacturer.



## 4. MAINTENANCE OF THE WHEEL

This chapter describes activities that affect the entire wheel:

- Truing the wheel
- Replacing a spoke

The description of a full hub service can be found in the technical manual of the respective hub at [www.dtswiss.com](http://www.dtswiss.com).

### 4.1 SERVICE INTERVALS

The following regular maintenance and care work is recommended by DT Swiss:

Task	Interval
Replace the Tubeless Ready Tape	12 months
Check Tubeless Ready Tape for damages. The Tubeless Ready Tape needs to be changed, when <ul style="list-style-type: none"><li>• the imprint comes off and the amber carrier material is visible (see figure) and / or</li><li>• strong bulges at the spoke holes are visible inwards and the tape wrinkles strongly at the spoke holes (see figure).</li></ul>	3 months
Check lateral and radial runout of the wheel.	10 operating hours
Check spoke tension.	6 months or as required
Clean with soft cloth and a suitable cleaner. → Do not use high pressure cleaners or aggressive cleaning agents!	After each ride
Check the wheel for damage	After each ride
Check that the wheels are secured correctly	before each ride
Check air pressure	

### 4.2 SAFETY



#### **DANGER**

#### **DANGER TO LIFE DUE TO INCORRECT MAINTENANCE AND INCORRECT SPARE PARTS!**

Unpredictable malfunctions can occur due to incorrect maintenance, incorrect installation or incorrect spare parts.

- Maintenance may only be carried out by experienced specialists.
- Use only original DT Swiss spare parts or spare parts approved by DT Swiss.
- In cases of doubt, please contact a DT Swiss Service Center.

### 4.3 PHR SYSTEM: BASICS

Some of the DT Swiss wheels are equipped with the PHR system. The DT Swiss PHR (PRO HEAD® REINFORCEMENT) system consists of a washer and a specially shaped nipple. The shape of the washer (PHR washer) acts as a ball joint and perfectly aligns the specially developed DT Squorx Pro Head® ball head nipple in the direction of pull, minimizing the risk of spoke breakage.

#### MOUNTING OF THE PHR SYSTEM

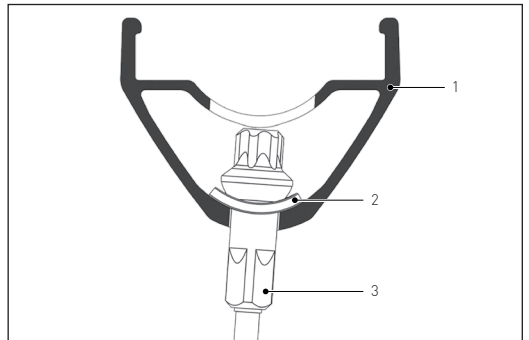
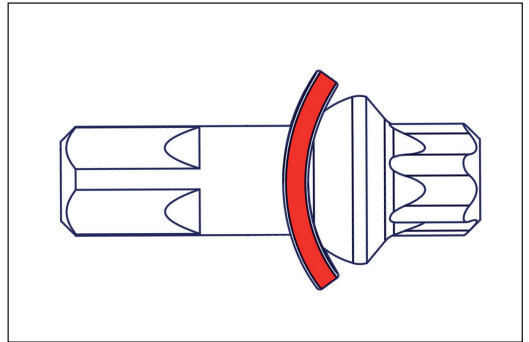
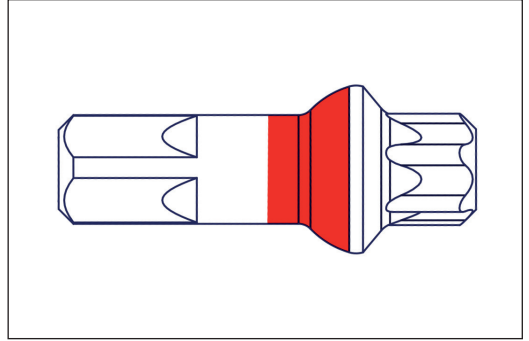

1. Grease the contact surface of the PHR washer and Squorx nipple with universal grease.
2. Slide the PHR washer onto the Squorx nipple. See figure for orientation.
3. Push the spoke through hub and rim.
4. Screw the Squorx nipple onto the spoke.
5. Check the alignment of the PHR washer. The bend of the PHR washer (2) must be within the radius of the rim (1).



## 4.4 REPLACING A SPOKE

Preparations	Link
Remove the wheel from the bike	See specifications of the respective manufacturer.
Dismount tire, tube and rim tape or tubeless tape	See specifications of the respective manufacturer.
Clean the wheel	See "Cleaning" on page 4.

### REQUIRED MATERIAL

Wearing parts / Materials	Specification	Quantity	Article number
Spokey square		1	TTSXXXXR05633S
Nipple key hexagonal		1	TTSXXXXB05632S
Nipple key Torx		1	TTSXXXXS05630S
Screw clamp		1	



If four spokes or more are replaced, the entire wheel should be rebuilt.

## REMOVING THE SPOKE TO BE REPLACED

1. Put the wheel in the truing stand.



As a basis for the following steps, it is assumed that the spoke is broken. If the spoke to be replaced is still intact, it can be cut with a cutter or similar.

2. Cut spoke with a cutter if necessary:
  - a. Release the spoke using a screw clamp.
  - b. Cut the spoke carefully.
  - c. Remove the screw clamp.



3. Check if there is a washer [PHR washer] on the nipple.
4. Pull out the first spoke part with the nipple through the rim.
  - If there is a PHR washer: Take care that the washer does not fall into the rim profile.



5. Pull out the second spoke end on the hub side.

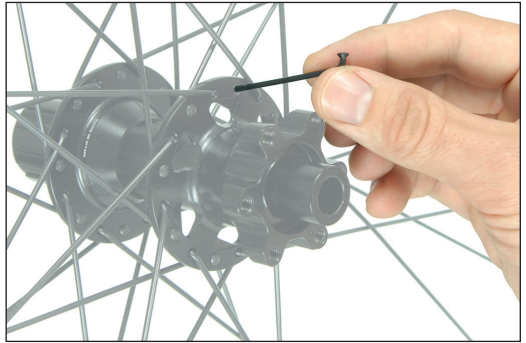

## ATTACHING A NEW SPOKE

1. Push new spoke through the spoke hole in the hub.
2. Attach a new nipple. When a PHR washer is used: Lightly grease the nipple, put the PHR Washer on the nipple and screw the nipple onto the spoke ("3.3 PHR System: Basics" on page 18).
3. Slide the Spokey onto the nipple.
  - To avoid damage to the nipple, always push the Spokey all the way onto the nipple.
4. Tighten the spoke.

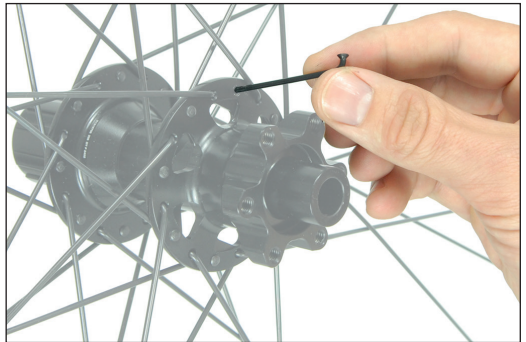

### Closing steps

True the wheel.

If necessary, mount tube and tire or tubeless system.

Mount the wheel in the bike if required.

### Link

See specifications of the respective manufacturer.

See specifications of the respective manufacturer.

See specifications of the respective manufacturer.

## 5. TROUBLE SHOOTING

### 5.1 TROUBLE SHOOTING HUBS

Issue	Reason	Solution
Freewheel jammed / blocked	Spacer was forgotten during assembly.	Check correct assembly, see "Mounting the freewheel system", page 14.
	Spacer was compressed by overtightening the thru axle.	Measure the length of the spacer. If the spacer is shorter than 15.4 mm, it must be replaced.
	An end cap that does not fit has been mounted.	Shimano end caps on a SRAM XD freewheel can cause jamming.
	Defects on the hub body, on the freewheel or on one of the end caps.	Check all parts for defects and replace parts as necessary.
Hub has axial play	Ball bearings were not mounted correctly.	Check correct assembly, see "2.3 Maintenance of the rear wheel hub with Ratchet System", page 11
	Ball bearings are worn out.	Replace ball bearings.
Hub rotates stiffly	Ball bearings are worn out.	Replace ball bearings.
	Ball bearing non drive side too tight.	Check correct assembly, see "2.3 Maintenance of the rear wheel hub with Ratchet System", page 11
	Mounting sequence of the ball bearings not observed.	
Hub makes noise	Ball bearings are worn out.	Replace ball bearings.
Notches from the cassette on the freewheel body.	The steel cassette works itself into the alloy web of the freewheel body.	Remove bad notches on the freewheel body using a file.
Freewheel body rotates with difficulty.	Ball bearings in the freewheel body are worn out.	Replace freewheel body.
	Stop of the cassette on the freewheel body broken.	Replace the freewheel body.
Freewheel is too noisy / too quiet.	The perception of the freewheel sound is very subjective. While some riders prefer a loud freewheel sound, other riders want a quiet freewheel. In principle, the freewheeling sound can be influenced by the amount of grease between the ratchets. Less grease increases the freewheeling sound, but at the same time leads to higher wear.	

## 5.2 TROUBLE SHOOTING WHEELS

<b>Problem</b>	<b>Reason</b>	<b>Solution</b>
Wheel has lateral or radial runout	Loose spokes or external force.	True the wheel and check spoke tension, adjust if necessary.
Wheel feels "soft"	Check maximum permissible system weight.	If exceeded, replace wheels with new ones corresponding to the system weight.
	Check spoke tension.	Correct if necessary
	Check clamping in the bike.	Tighten more strongly if necessary (axle or quick release).
Nipples loosen	Check maximum permissible system weight, ensure that this is not exceeded.	Re-build wheel with new PL nipples or Spoke Freeze.
Creaking noises from spoke crossings	Friction of the spokes at crossing points.	Short term: lightly grease/oil crossing points. Long term: have new spokes fitted by Service Center.
Clicking noise from nipple and / or PHR Washer	Worn-in nipples/PHR washers.	Have nipple and PHR washer replaced by Service Center.
Wheel jams, rotates sluggishly when quick release or axle is tightened.	Slammed spacer in the hub.	Replace spacer.
Air loss with TL setup	TL Tape perforated or otherwise damaged.	Apply new TL Tape.
Decreasing braking effect with rim brakes	Worn or dirty brake surfaces.	Clean braking surface and pads, replace rim if necessary.

## 6. TECHNICAL DATA

Further technical data, such as spoke types, spoke lengths etc., can be found in the Product Support Tool at [www.dtswiss.com](http://www.dtswiss.com).

Technical data of products from older model years can also be found in the DT Swiss Techbook.

### 6.1 SPOKE TENSION

Wheel type		max. permissible spoke tension of the higher tensioned wheel side [N]	min. permissible spoke tension of the higher tensioned wheel side [N]	average spoke tension of the higher tensioned wheel side [N]
Disc Brake Alu	Front wheel	1 200	950	1150 - 1000
	Rear wheel	1 300	1 050	1250 - 1100

### 6.2 TOLERANCES

Wheel type	Lateral runout [mm]	Radial runout [mm]	Dish [mm]
Aluminum welded	0.3	0.3	0.3
Aluminum sleeved	0.4	0.4	0.4



**DT SWISS AG**

Längfeldweg 101  
CH - 2504 Biel/Bienne  
service.ch@dtswiss.com

**DT SWISS, INC.**

2493 Industrial Blvd.  
USA - Grand Junction, CO 81505  
techusa@dtswiss.com

**DT SWISS (FRANCE) S.A.S.**

Parc d'Activites de la Sarrée  
Route de Gourdon  
F - 06620 Le Bar sur Loup  
service.fr@dtswiss.com

**DT SWISS ASIA LTD.**

No.5, Jingke 5th Rd., Nantun District  
Taichung City 408  
Taiwan (R.O.C.)  
service.tw@dtswiss.com

**DT SWISS DEUTSCHLAND GmbH**

Albert-Einstein-Strasse 3  
59302 Oelde  
Germany  
service.de@dtswiss.com

**DT SWISS POLSKA Sp. z o.o.**

ul. Towarowa 36  
PL-64-600 Oborniki  
Poland  
service.pl@dtswiss.com

Subject to technical alterations, errors and misprints excepted.

All rights reserved.

© by DT SWISS AG

[www.dtswiss.com](http://www.dtswiss.com)

WXD1000000859S